

CB Cart Bumper

Product Name

Cart Bumper – Model CB

Manufacturer

Alvarado Manufacturing Co., Inc.

12660 Colony St.

Chino, CA 91710

Telephone (909) 591-8431

Toll Free 800-423-4143

Fax (909) 628-1403

www.alvaradomfg.com

Email: information@alvaradomfg.com

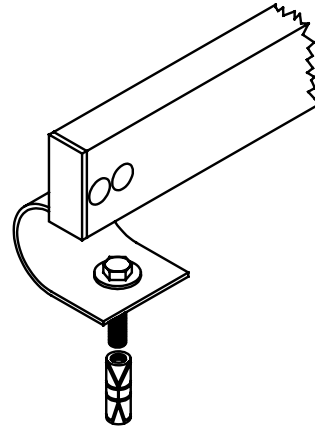

Product Description: The CB Cart Bumper is designed to provide case and wall protection.

Components:

- The **CB Rail** is a 4" high x 1.75" deep U-shaped channel made of 11-gauge cold rolled steel. Two (2) metal end caps that attach to the Spring Post are also included. The top of the CB Rail sits approximately 7.69" above the floor.
- The **Spring Post** is a single 4.5" wide piece of .190" thick spring steel treated to RC 40 to 50 that forms a half-circle at its base and extends approximately 4.92" from front to back. The upper portion of the Spring Post attaches to the CB Rail through four (4) square holes using bolts and lock nuts. The base of the Spring Post attaches to the floor through a single hole using the included Anchor Package.
- The **Anchor Package** consists of two (2) SA anchors with 5/8-11 x 3/4" bolts and washers. Each SA anchor is a 2.75" long x 1" diameter double-expansion system that expands to lock the anchor bolt securely in place.

Finishes: The CB rail is finished in polished chrome. The Spring Post is zinc plated.

Size: The CB Cart Bumper assembly has an overall height dimension of approximately 7.70" and is available in 2'0", 3'0", 4'0", 5'0", and 6'0" lengths.

Shipping: CB Rails are shipped with spring posts and SA anchors to mount the unit to a standard, level concrete floor. Alvarado ships products throughout the world.

Installation: All CB Cart Bumpers must be installed on level concrete. Installation should be performed by a skilled installer following the manufacturer's directions and instructions (supplied with the protector).

Corner Section Configurations:

The following is a list of corner section CB Bumper configurations that are available:

- **90° CB** – The CB rail is bent to a 90° angle with one side extending approximately 6.00” from the corner and the other side extending approximately 4.20” in the opposite direction.

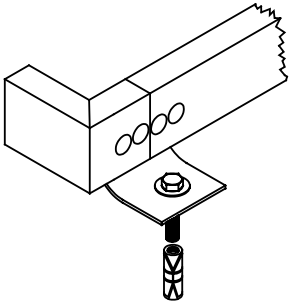

- **135° CB** – The CB rail is bent to a 135° angle with one side extending approximately 6.00” from the corner and the other side extending approximately 4.20” in the opposite direction.

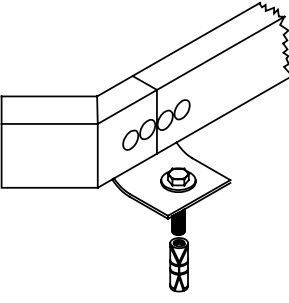

Warranty: Alvarado Manufacturing Co., Inc. warrants the CB Cart Bumper from defects in material or workmanship, for the period of ONE YEAR from date of shipment. Complete details of the warranty are available from Alvarado by request.

Technical Services: Technical information is available from Alvarado Mfg. Co., Inc., and its representatives, distributors and dealers.