

Alvarado's Model MT turnstile is the industry standard for single direction pedestrian traffic control and retail loss prevention.

The MT's familiar four-arm design provides a generous 20" patron passage width.

A no-slip clutch allows the turnstile arms to move smoothly and silently, using less than one pound of pressure.

Suitable for use in retail stores, schools, libraries, and other facilities, Model MT turnstiles are constructed from fully welded

tubular steel. Arm ends are welded with a steel cap, then ground/polished smooth.

The MT ships complete with turnstile head assembly and post, end post and connecting rail, plus a post-mounted curved yoke.

Factory-set clockwise arm rotation can be easily changed in the field for counter-clockwise rotation.

Standard finish is high-polish chrome, with optional satin stainless steel, or color powder coat finishes also available.



- **Smooth, Silent Rotation**
- **No-Slip Clutch**
- **Wide, Comfortable Passage Width**
- **Easy To Install**

ALVARADO

DESCRIPTION

PRODUCT NAME

Model MT - Manual, four-arm, single direction turnstile.

APPLICATIONS

Provides single direction pedestrian traffic control. Suitable for use in retail stores, libraries, schools and other applications.

PRODUCT FEATURES

Materials and Operation

- Heavy gauge materials meeting appropriate ASTM standards
- Tubular steel arms are sealed on the end with a welded steel cap, then ground and polished smooth.
- No-slip clutch provides single direction passage
- Smooth, silent rotation - arms can be moved using less than 1 lb. of pressure
- Clockwise arm rotation can be changed in the field to counter-clockwise



Finishes

- Standard finish is high-polish chrome
- Optional powder coat or satin stainless steel finishes are also available

MT OPTIONS

Rail Outlets - MT turnstiles may be ordered with factory-attached or loose rail outlets for installations that require integration with Alvarado post and rail systems.

Tandem Configuration - Dual turnstile assembly that uses less space than two standard single turnstile configurations.

WARRANTY

Alvarado's one-year written warranty applies to all products.

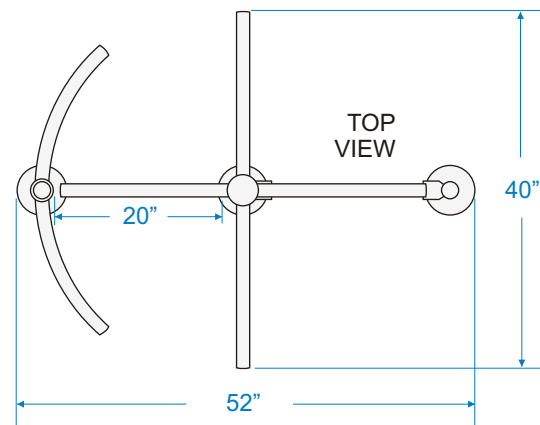

MT Dimensions

