

Alvarado's Model CSG is a heavy-duty, single direction, self-closing gate designed for use in retail stores, schools, libraries, and other applications.

Model CSG gates are easy to install, and feature fully welded stainless steel construction.

CSG gates open 90 degrees in a single direction, and provide a 36 inch passage width. The gate arm assembly is hinged with a rugged gravity closure mechanism to provide smooth, self-closing operation.

The versatile CSG can be installed as a stand-alone gate, or may be used in conjunction with post & rail systems.

Optional factory-attached or loose rail outlets are available for integration with your railing layout.

CSG gates may be ordered with right or left-hand gate swing.

Standard finish is bright polished stainless steel, with optional color powder coat finishes also available.



- **Gravity Action Self-Closing Design**
- **Passage Width of 36"**
- **Welded Stainless Steel Construction**
- **Single Direction - Right or Left Hand Gate Swing**

ALVARADO

DESCRIPTION

PRODUCT NAME

Model CSG - Single direction, gravity action self-closing gate.

APPLICATIONS

Suitable for use in retail stores, schools, libraries and other applications. May be installed as a stand-alone gate, or can be used in conjunction with post and rail systems.

PRODUCT FEATURES

Materials and Operation

- Heavy gauge materials meeting appropriate ASTM standards
- Fully welded stainless steel construction
- Single direction gate arm assembly uses gravity closure for smooth, self-closing operation
- Easy to install
- Gate posts secure to the floor with four anchor bolts



CSG gate shown in bright polished stainless steel

Finishes

- Standard gate finish is bright polished stainless steel (600 grit finish)
- CSG gates are also available in color powder coat finishes

CSG OPTIONS

Rail Outlets - CSG gates may be ordered with factory-attached or loose rail outlets for installations that require integration with Alvarado post and rail systems.

WARRANTY

Alvarado's one-year written warranty applies to all products.

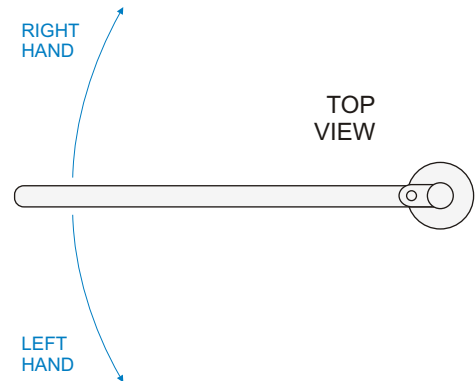

CSG Dimensions

