

# WWW.TURNSTILES.US

GSA Contract # GS-07F-9239S



# catrax

*plus*

Catrax Plus turnstile is the best access control solution available in the market. The models stand out for their versatility, attractive design and, especially, for their ease of integration with other security components, such as magnetic, biometric and proximity readers.



## Drop Arm System



Through an anti-panic mechanism the arm drops leaving the access free. This special feature can be used in emergency cases (activated through a push-button or system in a control room) or in case of power failure (when the turnstile does not have the no-break system). The turnstile can also inform the system when the arm drops.

## SPECIAL DESIGN



Catrax Plus turnstile pedestal has rounded corners and plenty of internal space to facilitate the assembly of electronic and other types of components. As access is gained by a key lock, there are no exposed screws.

## SMOOTHER PASSAGE

Arms with a 90-degree passageway allow for a smooth turn and lessen the impact of the turnstile arm on patrons after each passage.

## RELIABILITY AND SAFETY

Optical sensors and electromagnets are used to activate locks, thus preventing mechanical wear and increasing equipment life.

## CUSTOMIZED PRODUCTS



Catrax Plus top panel is manufactured in high impact engineering plastic and is available in black, Bordeaux red and green (special colors can be optionally supplied). The stainless steel cover allows for easy, low-cost configuration, and can be customized with the customer's own brand identity. The turnstile can also be equipped with bar code or magnetic card slot readers (optional).

[www.TURNSTILES.us](http://www.TURNSTILES.us)

[www.TURNSTILES.us](http://www.TURNSTILES.us) \* 8641 S. Warhawk Rd. \* Conifer, CO 80433

email: [patrick.mcallister@turnstiles.us](mailto:patrick.mcallister@turnstiles.us)



## EASILY MOUNTED AND MAINTAINED



The Catrax Plus turnstile comes with a U-shaped mounting drawer that can be easily removed or replaced on the rear top panel by a key lock, thus facilitating the assembly and maintenance of electronic components.

## ACCESS PERMISSION



Catrax Plus can be configured with pictograms to inform access permission and detect direction of movement.

## EASY PROGRAMMING



Optional microprocessor controller board allows for total integration with a variety of available solutions access denied.

## DIMENSIONS

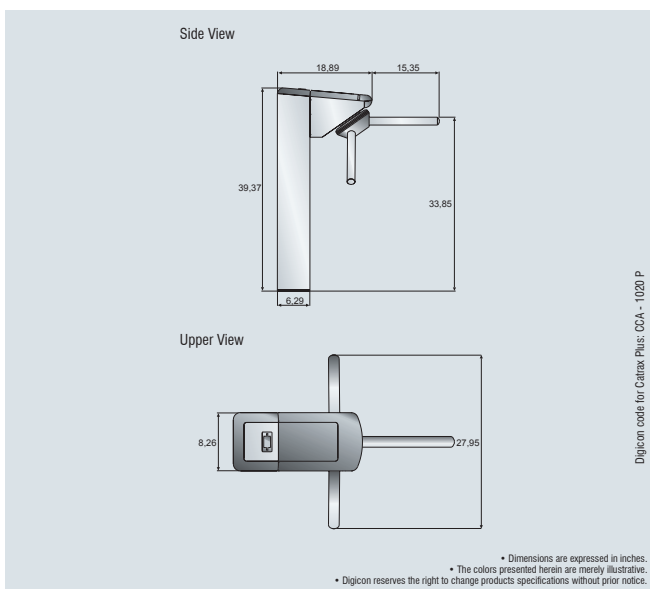

## TECHNICAL CHARACTERISTICS

- Locking mechanism activated by electromagnets instead of solenoids, giving greater reliability;
- Rotation signals generated by high output optical sensors, completely avoiding mechanical wear;
- Cabinet made of carbon steel, with electrostatic powder coating or, optionally, of brushed stainless steel (AISI 304). Arms manufactured in polished stainless steel;
- The top cover consists of a stainless steel plate, finished with high impact injection-molded plastic parts, offering strength and rounded corners, along with excellent appearance;
- No visible screws: access to the internal components of the turnstile is by lock and key;
- Two automotive grade roller bearings increase equipment life, avoiding unnecessary maintenance;
- High performance mechanism for operation under heavy traffic flow;
- Turnstile rotates freely in case of emergency or power failure;
- Easily adapted and integrated to any terminal/technology. Catrax Plus allows for easy installation of barcode, proximity or Smart Card readers on the upper surface or side of cover;
- Optional SMD assembled controller board (interface between the turnstile and integrator electronics control), with configurable electromagnet protection system offering 4 inputs and 2 outputs. It allows four turnstile configurations: forward rotation, backward rotation, rotation in both directions and locked in both directions. In addition, the controller board allows time outs and returns signals, informing the passage of a user;
- Optional switching power supply – input between 90 and 250 VAC and output of 12 VDC/2A, with protection against electrical surges;
- Pictograms for visual signaling indicate access allowed (green arrow) or access denied (red “X”);
- Optional card collection unit can be integrated into the turnstile. The collection box has an infra red card detection device, an electromagnetic device to retain and collect cards, and a container to store up to 200 cards. Access to the container is through locked door key. The unit also contains a window for card reader installation;
- Optional no-break system allows the turnstile to work for a period of up to 4 hours. The no-break charges a battery and has a shut down device in case of emergency.

[www.TURNSTILES.us](http://www.TURNSTILES.us)

[www.TURNSTILES.us](http://www.TURNSTILES.us) \* 8641 S. Warhawk Rd. \* Conifer, CO 80433

email: [patrick.mcallister@turnstiles.us](mailto:patrick.mcallister@turnstiles.us)